

OPERATING INSTRUCTIONS AND SAFETY NOTES

PREMAxx · Diesel Pump

230 V · 24 V-DC · 12 V-DC



FMT  Swiss AG

FMT Swiss AG

This documentation is exclusively intended for the operating company and their staff.

Without our written consent, the content of this documentation (textes, figures, drawings, charts, diagrams etc.), must not be duplicated or distributed, neither in full or in part, utilized for the purpose of competition or passed on/made available to third parties.

FMT Swiss AG

Fluid Management Technologies Swiss AG

Gewerbestraße 6

6330 Cham / Schweiz

Tel. +41 41 712 05 37

Fax +41 41 720 26 21

Email: info@fmtag.com

Internet: www.fmtag.com

Operating instructions translation

Date of issue: 05/2020

We reserve the right to make design and product modifications, which serve to improve the product.

Table of Contents

1.	Introduction	4
1.1.	Preface	4
1.2.	Obligations of the personnel	4
1.3.	Symbols in this manual	4
1.3.1.	Structure of the warning notes	4
1.3.2.	Hazard warning symbols	5
1.3.3.	General symbols	5
2.	Safety notes	5
2.1.	Authorized personnel	6
2.2.	Notes for maintenance, cleaning and repair	6
2.3.	Intended conditions of use	6
2.4.	Risks when handling the PREMAxx diesel pump	7
2.5.	Risks when handling diesel and heating oil	7
3.	Transport and temporary storage	8
4.	Design and functional description	8
4.1.	Area of application	8
5.	Technical data	8
6.	Installation	9
7.	Operation	11
7.1.	First and re-commissioning	11
8.	Preventive maintenance	12
9.	Maintenance	12
10.	Troubleshooting	13
11.	Repair/Service	13
12.	Disposal	13
13.	Exploded view of the PREMAxx diesel pump 230 V	14
14.	Exploded view of the PREMAxx diesel pump 24 /12 V	16
15.	EC Declaration of Conformity	18

1. Introduction

1.1. Preface

Please carefully read these operating instructions and observe in particular all safety notes!

Our staff will be pleased to provide support if you have any questions about the product.

Yours sincerely, FMT Swiss AG

1.2. Obligations of the personnel

Before they start to work, all persons who are entrusted with work with the PREMAXX diesel pump, are obliged:

- to follow all applicable regulations on occupational safety and accident prevention.
- to read and to comply with all safety instructions and warning notes contained in these operating instructions.

Please observe the following instructions in the interest of all concerned:

- Refrain from any unsafe working methods!
- Adhere to all hazard and warning notes contained in this manual!
- In addition to this documentation, keep to all generally accepted safety rules, legal provisions as well as all other binding rules regarding occupational safety, accident prevention and environmental protection!
- Wear appropriate protective clothing in accordance with the work to be done!
- Perform only work for which you have been sufficiently trained and instructed!
- Only genuine spare parts as well as original tools and auxiliaries of the manufacturer are allowed to be used in order to ensure the functional safety and maintain the warranty coverage.

1.3. Symbols in this manual

1.3.1. Structure of the warning notes

The warning notes have the following structure:



SIGNAL WORD

Type and source of the hazard

- Consequences of non-compliance with the notes
- Measures to avoid that risk

Depending on the danger level, different signal words are used:

Signal word	Danger level	Consequences of non-compliance
DANGER	Imminent threat of danger	Death or serious bodily injury
WARNING	Possible threat of danger	Death or serious bodily injury
CAUTION	Possibly dangerous situation	Minor bodily injury
ATTENTION	Possibly dangerous situation	Damage to material property



NOTE

Indicates further information or tips which facilitate work.

1.3.2. Hazard warning symbols

Symbol

Meaning



General hazard symbol. The warning note marked in this way contains supplementary information on the type of hazard.



This symbol warns of dangerous electrical voltages.



This symbol warns of a hazardous explosive atmosphere.

1.3.3. General symbols

Symbol

Meaning



A small black square indicates the work you have to perform.



The dash denotes lists.



The arrow identifies cross-references.

If cross-references to other chapters are required within the text, the expression is shortened for reasons of clarity.

Example: ⇒ Chapter 2 Safety notes

This means: please refer to chapter 2 for the safety notes

2. Safety notes

Various dangers may occur if the PREMAxx diesel pump is improperly handled during installation, commissioning and daily operation.



WARNING

Risk of injury and damage to material property because of improper handling!

- Hold the instructions at the disposal of the operating staff at the usage site of the unit.
- Country-specific safety measures and accident prevention regulations must be observed.

2.1. Authorized personnel

Only qualified and authorized persons are allowed to operate and to work on the PREMAxx diesel pump.

Persons are qualified if they are, due to their training, experience, instruction and knowledge of the relevant standards, able to assess assigned tasks and to identify potentially hazardous situations.

These persons must have been authorized by the person responsible for the safety of the unit and must be able to identify and to avoid potential dangers.

All persons charged with installation, operation, maintenance and repair work, must have read and understood this operation manual.

A copy of this operating manual must be stored permanently and ready at hand at the place of usage of the pump.

2.2. Notes for maintenance, cleaning and repair



WARNING

Risk of injury and damage to material property because of improper maintenance and repair!

- Keep to the specified inspection and maintenance intervals (⇒ **Chapter Maintenance**).
 - Should unusual noises occur, immediately stop the pump. Immediately identify and eliminate the cause in order to avoid consequential damages.
 - Observe the safety sheet for diesel and heating oil.
-

2.3. Intended conditions of use

The PREMAxx diesel pump is an electrically driven axial gear pump for the delivery of diesel fuel and heating oil.

The temperature of the conveying liquid must be between -10 °C and $+35\text{ °C}$.

Pumping of explosive fluids is forbidden.

The use in the food industry is forbidden.

The pump may only be connected to a suitable power source (see nameplate).

Proper usage also includes complying with the operating manual, which must be completely read before the unit is put into operation.

Any departure from the usage stipulations (other fluid media, use of force) or user modifications (changes, use of non-original parts) can be dangerous and are considered as non-intended usage.

The user is liable for any damage resulting from non-intended use.

During repairs to any electrical components, the appropriate safety and test requirements are to be observed.

Only genuine replacement parts are to be used for any repairs, because otherwise the warranty will be invalidated.

Use of the pump only in compliance with the intended conditions of use.

Any application beyond the intended use can lead to hazardous situations and shall be regarded as non-intended use.



DANGER

Risk of injury and material damage from explosive vapors!

- **Never use the pump to deliver fatty substances or explosive fluids such as petrol or other fluids with similar flashpoints!**
- Since the motor and the switch **are not** explosion-protected, the pump must **not be** operated in an explosion risk area.
- Pumping caustic or other hazardous chemical or biological substances is forbidden.
- Do **NOT** use the pump in an explosion-risk area. **No** open fire, no smoking. Use the pump exclusively for delivering diesel fuels or heating oils.

2.4. Risks when handling the PREMAxx diesel pump



DANGER

Risk of injury and material damage because of improper installation, electric current or contaminated media!

Never work on a pump that is running!

- Mount or remove attachments and accessories only when the pump is switched off from all sources of energy.
- Before the pump is put into operation, this one must be tightly screwed to the dispensing container.
- The pump is only allowed to be operated, if it is screwed to the dispensing container and thus cannot carry out any uncontrolled movements.
- The pump is only allowed to be operated if the dispensing container, to which the pump is connected, stands on a firm and level surface.
- For your own safety, disconnect the pump in addition from the power supply.
- Never leave the pump unattended.
- Check to ensure that the pump does not work against the closed nozzle

Do not pump contaminated fluids

- Take special care to ensure that there are no contaminants in the fluid to be pumped.
- Install a strainer on the suction pipe.

Damaged attachments and accessories can lead to personal injury and material damage

- Attachments and accessories must be checked for wear, splits or other damage throughout their period of use.
- Damaged accessories and attachments must be replaced immediately.
- With reference to the period of use, please note the details in ZH 1/A45.4.2 or DIN 20066 Part 5.3.2

Escaping liquids can cause environmental harm

Comply with the stipulations of the German Water Resources Act (WHG) and of the Plant Regulations of the German federal states (VawS).

2.5. Risks when handling diesel and heating oil

Diesel fuels and heating oils are flammable liquids. If improperly handled, they can cause risks to human health or to the environment.



NOTE

Observe the safety sheet for diesel and heating oil!

3. Transport and temporary storage

Before transport, ensure that there is no liquid (diesel or heating oil residues) in the pump. All additional extensions must be removed from the pump.

Do not use the cable to transport the pump!

Storage and transport conditions:

- Weather-protected storage with temperature control, protection against frost, moisture and rain. Maximum relative humidity: 80 %.
- Storage temperature range from -5 °C bis +55 °C

4. Design and functional description

The PREMAxx diesel pump is an electrically driven axial gear pump for the delivery of diesel fuels and heating oil. It is only designed for use as a barrel pump and can be screwed on storage barrels and containers. The PREMAxx diesel pump is not a self-priming pump.

Operate the pump by hand before putting the pump into operation for the first time or if the fluid column has dropped down, because the radial shaft seal may be destroyed by a dry run of the pump.

The pump is compact and handy and quickly ready for use thanks to its integrated priming stage, which allows to manually pump small quantities of fluid before commissioning or in case of a power failure.

To avoid environmental damage, the electric PREMAxx diesel pump is equipped with a siphon protection system.

In case the discharge hose is damaged while the pump is stopped, siphon action will prevent the fluid from escaping.

The pump housing is made of high-quality, impact-resistant plastic.

Numerous accessories from FMT allow a simple and quick mounting on each installation.

The materials the pump is made from are compatible with fluids like diesel fuel and heating oil.

The pump is electrically driven by an alternating current motor suitable for continuous operation. The pump is directly flange-mounted to the motor. In case of overload, a thermal protection device automatically switches off the electric motor.

When the motor has cooled down, the thermal protection device automatically restarts.

Pump data ⇒ Chapter „Technical data“.

The PREMAxx diesel pump is available in the following versions:

- **Premaxx, 48 l/min-12.6 gpm 230 V-1~AC-50 Hz**
- **Premaxx, 35 l/min-9.2 gpm 12 V-DC battery terminal clips**
- **Premaxx, 40 l/min-10.5 gpm 24 V-DC battery terminal clips**

4.1. Area of application

The PREMAxx diesel pump is an electrically driven pump for the delivery of diesel fuels and heating oil. It is only designed for use as a barrel pump and can be screwed on storage barrels and containers.

The temperature of the delivery fluids must be between -10 °C and + 35 °C. The temperatures must not be above or below these limit values.

Since the motor and the switch are not explosion-protected the pump **must not** be operated in an explosion risk area.

5. Technical data

Description	230 V 23 730	12 V 23 710	24 V 23 720
Connecting cable, length (m) (ft)		2 / 6.6	
Connection container		G 2" male, drum adapter	
Connection suction side		Hose fitting DN 19	
Connection discharge side		G 1" male	
Hydraulic data			
Pump design		axial gear	
Delivery rate under free discharge (l/min) / (gpm)	48 / 12.6	35 / 9.2	40 / 10.5
Suction height (m) / (ft)		2,5 / 8.2	
Discharge height max. (m) / (ft):		15 / 49.2	
Pumping media		heating oil and diesel fuels	
Temperature range of pumping media		-10 °C / +35 °C	
Motor data			
Voltage (V)	230	12 DC	24 DC
Frequency (Hz)	50		
Power consumption (A)	1,8	14	10
Power (kW)	0,42	0,18	0,24
Thermal protection		self resetting	
Duty cycle (min):		30	
Rotation speed at 0,5 bar counterpressure (rpm)	10000	7500	7500
Type of construction		IMB 5	
Protection class		IP 34	
Material of pump housing and pump	PA 6 PA6 GF30	PA 6 PA6 GF30	PA 6 PA6 GF30
Dimensions of pump LxWxH (mm) / (inch)		130 x 130 x 350 / 5.1 x 5.1 x 13.7	
Weight (kg) (lbs)		2,5 / 5.5	

Tab. 5-1: Technical data

6. Installation

The Premaxx diesel pump is designed for installations in indoor and outdoor areas.

The installation must be carried out in the following sequences (see fig. 6-1):

- Push the suction hose (2) on the suction tube (11) with filter (1).
- Push the hose clamp (10) over the suction hose (2) to the suction tube (11) and fasten the hose clamp by means of a screwdriver.



NOTE

Before proceeding to the next step, please note the following:

When the pump is mounted on the storage container, the suction hose with the suction tube must be long enough to reach the liquid in the storage container even when the fluid level is low.

- Cut the suction hose (2) to the desired length.
- Push the hose clamp (18) over the suction hose (2).
- Push the suction hose (2) on the suction port (19) on the pump.
- Push the suction clamp (18) to the suction port (19) and fasten the hose clamp by means of a screwdriver.



NOTE

Do not overtighten the hose clamp at the suction port, because otherwise the check valve may be jammed and the pump may stop working.



CAUTION

Risk of injury through incorrect installation!

- Mount and operate the pump only in vertical position on a storage container.
 - The pump is only allowed to be operated if it is firmly screwed with the dispensing container, so that it cannot carry out any uncontrolled movements.
 - The pump is only allowed to be operated if the dispensing container, to which the pump is connected, stands on a firm and level surface.
-
- Screw the pump firmly into the opening of the storage container by means of the barrel screw coupling (20).
 - When screwed in, the pump outlet can be moved to any desired position by turning the pump housing (5).
 - Screw the union nut (13) of the black discharge hose down to the discharge port (21) of the pump.
 - Screw the free end of the discharge hose with the male thread (8) into the thread of the nozzle valve (6 or 7).

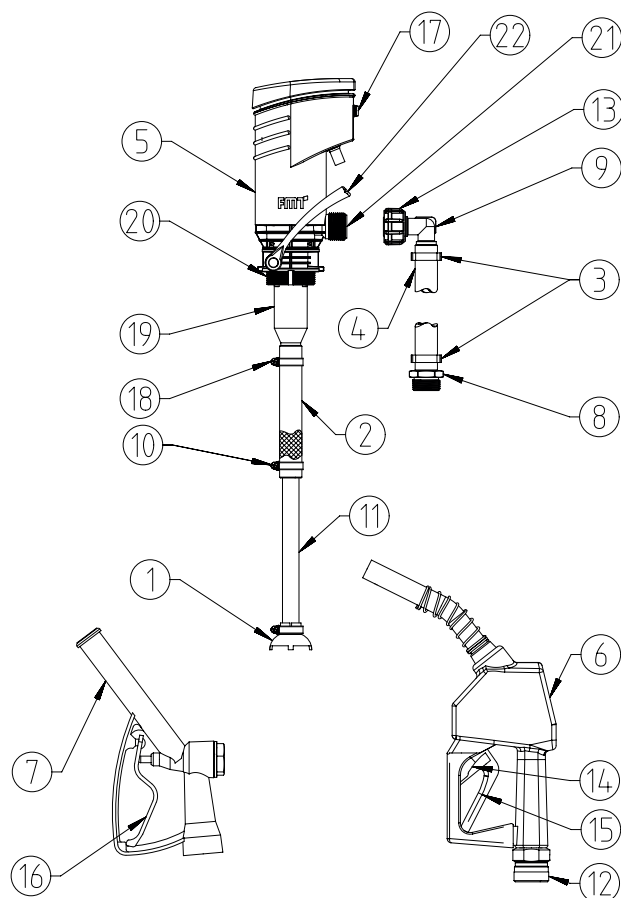

Fig. 6-1: Overview of the PREMAxx diesel pump with accessories

1	Suction filter with metal screen	12	Easy-turn swivel joint-DN 19
2	Hose for diesel, DN 19	13	Nut G1"
3	2-ear hose clamp	14	Lock
4	Hose for diesel, DN 19	15	Lever, automatic nozzle valve
5	PREMAxx diesel pump	16	Lever, standard nozzle valve
6	Automatic nozzle valve, diesel	17	On/off rocker switch
7	Nozzle valve-G 1" female-80 l/min	18	Worm drive clamp
8	Press nipple	19	Intake pipe socket
9	Bend 90°	20	Barrel screw coupling
10	Worm drive clamp	21	Discharge port
11	Intake pipe socket for PREMAxx	22	Hand lever

- Connect the pump to a power source using the mains plug or the terminal clamps.

The pump is ready for commissioning.



CAUTION

Risk of injury from 24 V and 12 V batteries!

- When handling the 24 V and 12 V battery (lead-acid battery), observe the specifications and the material data safety sheet of the battery manufacturer.

Carry out the following steps when connecting the pump (24/12 V) to the battery:

- The switch of the pump must be in the OFF position.
- Remove the protection cap from the positive battery terminal (+).
- Connect the red terminal clamp to the positive battery terminal.
- Remove the protection cap from the negative battery terminal (-).
- Connect the black terminal clamp to the negative battery terminal.

Proceed in reverse order when disconnecting the pump from the battery:

- At first, disconnect the black clamp from the negative terminal and then the red clamp from the positive terminal.
- Put the protection caps on the terminals again.

7. Operation

7.1. First and re-commissioning

Check the operativeness of the pump before use and after a failure-related or scheduled downtime.

Check the PREMAxx diesel pump and the installed accessories for completeness and damage. Replace any damaged components immediately. Never use a pump if damaged.



NOTE

- Operate the pump by hand before putting the pump into operation for the first time or if the fluid column has dropped down, because the radial shaft seal may be destroyed by a dry run of the pump.

Preparing the pump for operation (see fig. 6-1):

- Hold the nozzle valve (6 or 7) into a container.
- Push the lever (15 or 16) and keep it pushed or fix it by the lock (14) (if equipped with automatic nozzle valve). Hold the nozzle valve into the container to be filled.

- Manually pump fluid by means of the hand lever (22) until fluid is pumped out of the nozzle valve (6 or 7). Due to the integrated siphon protection, the fluid column may drop in case of long periods of disuse so that a manual pumping may be necessary again.
- Actuate the rocker switch (17) to switch on the pump.



NOTE

Danger of product damage

- Never operate the pump without liquid. The PREMAxx diesel pump may be damaged by running dry.
- Mount and operate the pump only in vertical position on a storage container.
- The diesel axial gear pump does not switch off automatically, therefore never let the pump running without supervision during filling operations.

- For finishing the filling operation, release the nozzle valve control lever. Never operate the pump for longer than 3 min with closed nozzle valve.
- Operate the rocker switch to switch off the pump.
- Position the nozzle valve so that no media can pollute the environment.

8. Preventive maintenance

In general, the PREMAxx diesel axial gear pump is very easy to maintain and to service. Maintenance work has always to be done by qualified technical personal.



ATTENTION

Danger of contact with energized components!

- When working on the electrical system of the pump, disconnect the pump in addition from the power supply and protect it against restarting.

Due to the operator responsibilities according to § 19i WHG (German Water Resources Act) the following components must be regularly checked and replaced as necessary to minimise the risk of environmental or equipment damage or personal injury:

- Pump housing
- Delivery hose
- Nozzle valve

9. Maintenance

Maintenance must be done by qualified technical personnel. External impact may cause a loss of performance, constitute a risk of damage to persons and/or property and void the guarantee.

Observe the following recommendations for operating the pump:



ATTENTION

Danger of contact with energized components!

- Before performing any maintenance work, disconnect the PREMAxx diesel pump from all electric and hydraulic supply sources
- When working on the electrical system of the pump, disconnect the pump in addition from the power supply and protect it against restarting.

- Always wear personal protective equipment when carrying out maintenance work.
- If there is danger of freezing, the pump and the circuit must be emptied and stored at a location with a temperature not lower than 0 °C / 32 °F.

- Check to ensure that the labels and decals have not become illegible and have not come loose in the course of time.
- Check at regular intervals that the line connections have not worked loose in order to avoid that liquid escapes.
- Regularly check and clean the suction line filter.
- From time to time, check the pump housing and remove any dirt.
- Check to ensure that the power cables are in perfect working order.

10. Troubleshooting

Malfunction	Cause	Solution
Motor does not run	▶ No power supply	▶ Check the electric connections
Discharge rate too low	▶ Discharge hose kinked or clogged ▶ Suction line resistance too high ▶ Filter resistance too high ▶ Nozzle valve not completely open	▶ Check the discharge hose ▶ Check the suction line, it may be kinked or clogged ▶ Check the suction filter and the check valve ▶ Check and clean the suction filter ▶ Completely open the nozzle valve

Tab. 10-1: Troubleshooting

11. Repair/Service

The PREMAxx diesel pump was developed and produced according to the highest quality standards. Should a problem develop, despite all quality controls, please contact our customer service:

FMT Swiss AG

Tel +49 9462 17-216

Fax +49 9462 1063

service@fmtag.ch

12. Disposal

The operating company is responsible for the proper disposal of the pump.

Hereby, the industry-specific and local regulations must be observed when disposing of the different materials.

Only qualified personnel is authorized to disassemble and dispose of the PREMAxx diesel pump.

13. Exploded view of the PREMAxx diesel pump 230 V

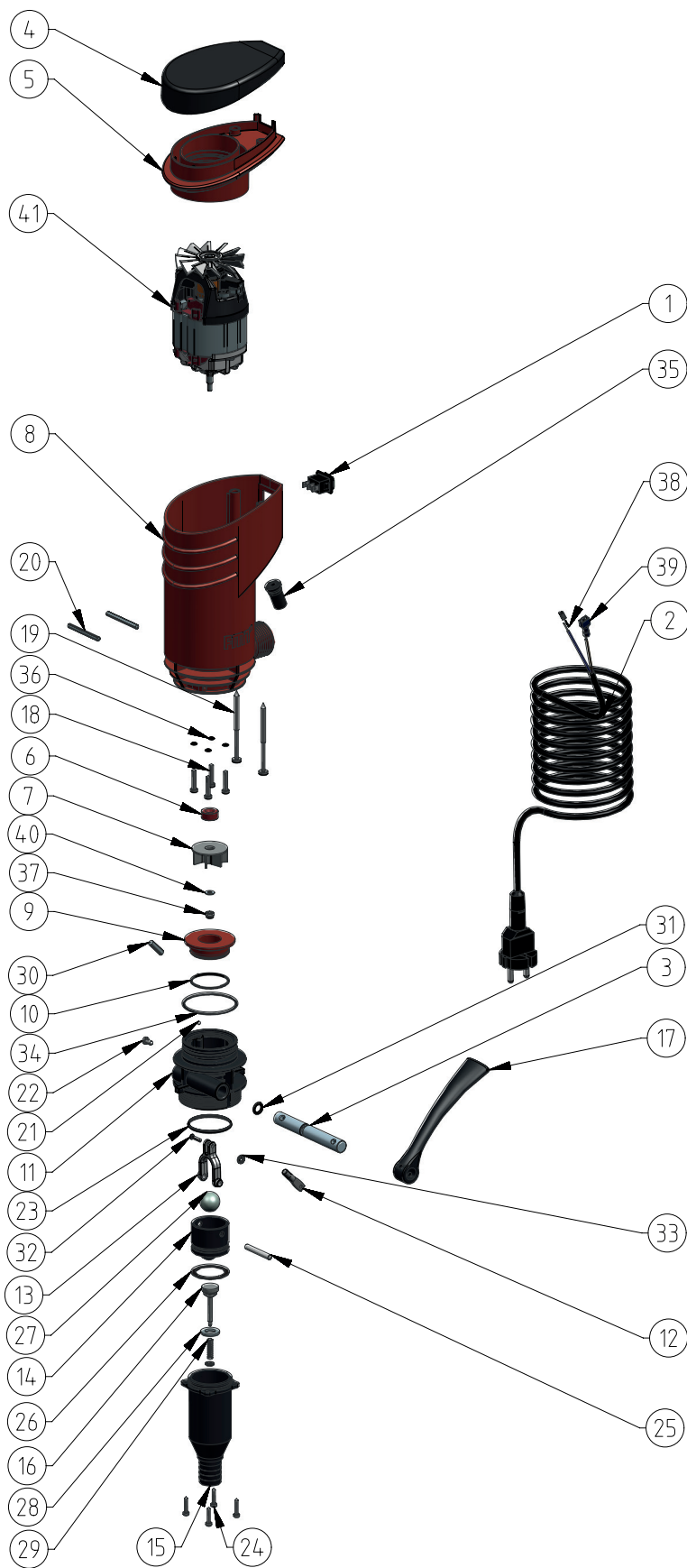

Fig. 13-1: Exploded view of the PREMAxx diesel pump 230 V

Pos.	Quantity	Description PREMAxx 230 V
1	1	Rocker switch, illuminated in green
2	1	Cable H05 RN F2 G 1,0-2 m
3	1	Pump shaft PREMAxx
4	1	Housing cover PREMAxx
5	1	Intermediate cover pump
6	1	Shaft seal ring DIN 3760
7	1	Impeller for PREMAxx
8	1	Housing PREMAxx
9	1	Spacer
10	1	O-ring NBR 70-31x2,2
11	1	Fitting
12	1	Threaded bolt
13	1	Con-rod for PREMAxx pump
14	1	Piston PREMAxx pump
15	1	Pump cylinder
16	1	Valve cone
17	1	Lever PREMAxx
18	4	Screws 4x20
19	2	Chipboard screw 4,5x70/40
20	2	Grooved taper pin DIN 1471
21	1	Ball stainless steel
22	1	Tapping screw 3,9x9,5
23	1	O-ring NBR 70-35 x2
24	4	Chipboard screw 3x16
25	1	Con-rod bolt Premaxx pump
26	1	Piston seal
27	1	Ball stainless steel, D = 19,05 mm
28	1	Flat seal
29	1	Compression spring
30	1	Grooved taper pin DIN 1471
31	1	O-ring NBR 70-7x2,5
32	1	Rivet DIN 660
33	2	Safety washer
34	1	O-ring FKM 80
35	1	Cable sleeve support
36	4	O-ring NBR 70-4x1
37	1	Nut DIN 985
38	1	Blade receptacle DIN 46345
39	1	Blade receptacle DIN 46245
40	1	Washer DIN 125A
41	1	Electric motor -230 V-50/60 Hz

Tab. 13-1: Overview of the components of fig. 13 -1

14. Exploded view of the PREMAxx diesel pump 24 / 12 V

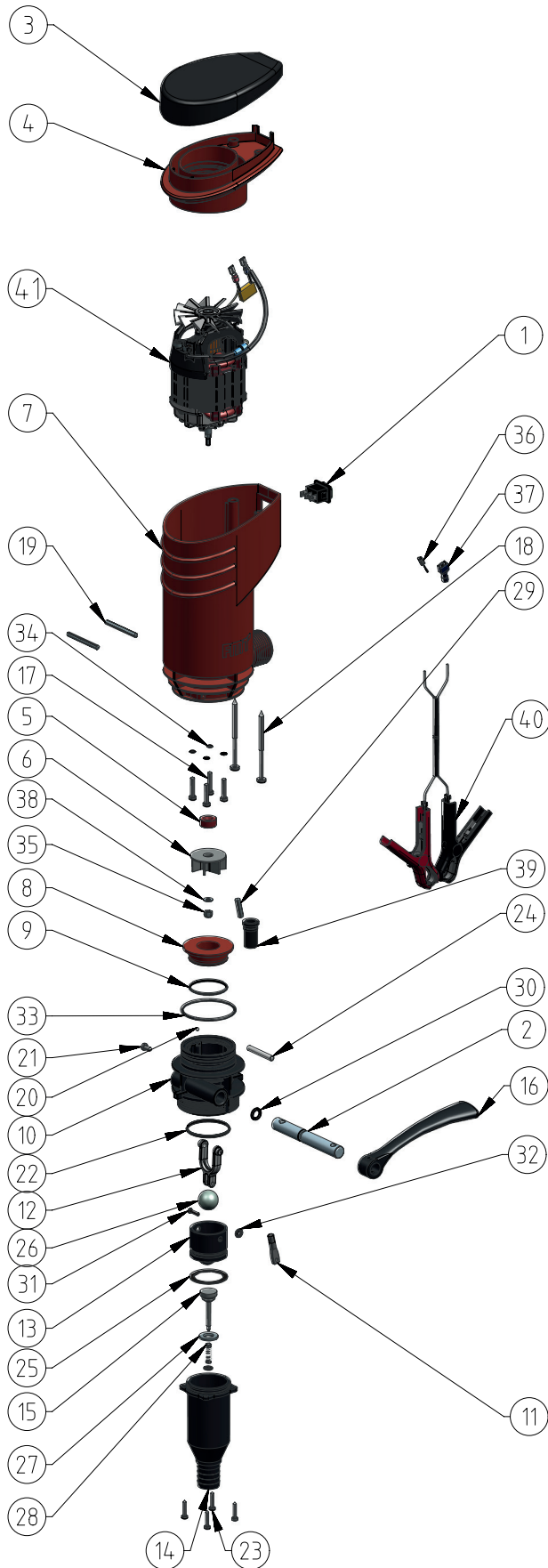

Fig. 14-1: Exploded view of the PREMAxx diesel pump 24 / 12 V

Operating Instructions - PREMAxx Diesel Pump GB

Pos.	Quantity	Description PREMAxx 24 V	Description PREMAxx 12 V
1	1	Rocker switch, illuminated in green	Rocker switch, illuminated in green
2	1	Pump shaft PREMAxx	Pump shaft PREMAxx
3	1	Housing cover PREMAxx	Housing cover PREMAxx
4	1	Intermediate cover pump	Intermediate cover pump
5	1	Shaft seal ring DIN 3760	Shaft seal ring DIN 3760
6	1	Impeller for PREMAxx	Impeller for PREMAxx
7	1	Housing PREMAxx	Housing PREMAxx
8	1	Spacer	Spacer
9	1	O-ring NBR 70-31x2,2	O-ring NBR 70-31x2,2
10	1	Fitting	Fitting
11	1	Threaded bolt PREMAxx pump	Threaded bolt PREMAxx pump
12	1	Con-rod for PREMAxx pump	Con-rod for PREMAxx pump
13	1	Piston PREMAxx pump	Piston PREMAxx pump
14	1	Pump cylinder	Pump cylinder
15	1	Valve cone	Valve cone
16	1	Lever PREMAxx	Lever PREMAxx
17	4	Screws 4x20	Screws 4x20
18	2	Chipboard screw 4,5x70/40	Chipboard screw 4,5x70/40
19	2	Grooved taper pin DIN 1471	Grooved taper pin DIN 1471
20	1	Ball stainless steel	Ball stainless steel
21	1	Tapping screw 3,9x9,5	Tapping screw 3,9x9,5
22	1	O-ring NBR 70-35x2	O-ring NBR 70-35x2
23	4	Chipboard screw 3x16	Chipboard screw 3x16
24	1	Con-rod bolt PREMAxx pump	Con-rod bolt PREMAxx pump
25	1	Piston seal	Piston seal
26	1	Ball, D = 19,05 mm	Ball, D = 19,05 mm
27	1	Flat seal	Flat seal
28	1	Compression spring	Compression spring
29	1	Grooved taper pin DIN 1471	Grooved taper pin DIN 1471
30	1	O-ring-FKM 70 - 7x2,5	O-ring-FKM 70 - 7x2,5
31	1	Button head rivet DIN 660	Button head rivet DIN 660
32	2	Washer	Washer
33	1	O-ring FKM 80	O-ring FKM 80
34	4	O-ring FKM 70 - 4x1	O-ring FKM 70 - 4x1
35	1	Hexagon nut DIN 985	Hexagon nut DIN 985
36	1	Blade receptacle DIN 46345	Blade receptacle DIN 46345
37	1	Blade receptacle DIN 46245	Blade receptacle DIN 46245
38	1	Washer DIN 125 A	Washer DIN 125 A
39	1	Cable sleeve support	Cable sleeve support
40	1	Cable with terminal clips-3 m	Cable with terminal clips-3 m
41	1	Electric motor 24 V	Electric motor 12 V

Tab. 14 -1: Overview of the components of fig.14-1

15. EC Declaration of Conformity



Manufacturer:

FMT Swiss AG

Fluid Management Technologies Swiss AG

Gewerbestraße 6

6330 Cham / Switzerland

Declares under his sole responsibility that the machine:

Model type	PREMAxx diesel pump 23 730 (230 V) 23 720 (24 V) 23 710 (12 V)
Motor voltage	230 / 24 / 12 V
Weight	2,5 kg
Power	23 730 (230 V) - 0,42 kW 25 720 (24 V) - 0,24 kW 23 710 (12 V) - 0,18 kW
Function	Pumping of diesel fuel and heating oil
Complies with all relevant provisions of the following directives:	
EC Directives	2006/42/EG Machinery Directive 2011/65/EC EU-Directive (RoHS)
Applicable standards	EN 809:1998+A1:2009+AC:2012 EN ISO 12100:2010 EN 60204-1:2006+A1:2009 EN 60335-1:2012+A11:2014

Authorized representative for the compilation of the technical documentation:

Name: Manuel Bredenbruch
Address: Fluid Management Technologies Swiss AG
Gewerbestraße 6
6330 Cham / Switzerland
Phone: +49 09462/ 17 -218

FMT Swiss AG
Cham, 19.05.2020

Dipl.-Ing. Rudolf Schlenker
(Managing Director)

FMT Swiss AG

Fluid Management Technologies Swiss AG

Gewerbestraße 6

6330 Cham / Schweiz

Tel. +41 41 712 05 37

Fax +41 41 720 26 21

info@fmtag.com

www.fmtag.com